

ITEM NO.	PART NUMBER	DESCRIPTION	QTY.
1	3086_AA	RECESS MOUNT BRKT WRAPPER	1
2	3086_AB	RECESS MOUNT BRKT END CAP	2
3	3086_AC	RECESS MOUNT BRKT BACKER PLATE	1
4	6MM_HIPS_DOWEL	6mm DIA LOCATOR DOWEL PIN	2
5	UB000832-185	DODGE 8-32 BRASS INSERT .185 LONG	2
6	SJ4570	1/2" DUO LOCK (SKU-120VCSJ4570)	2

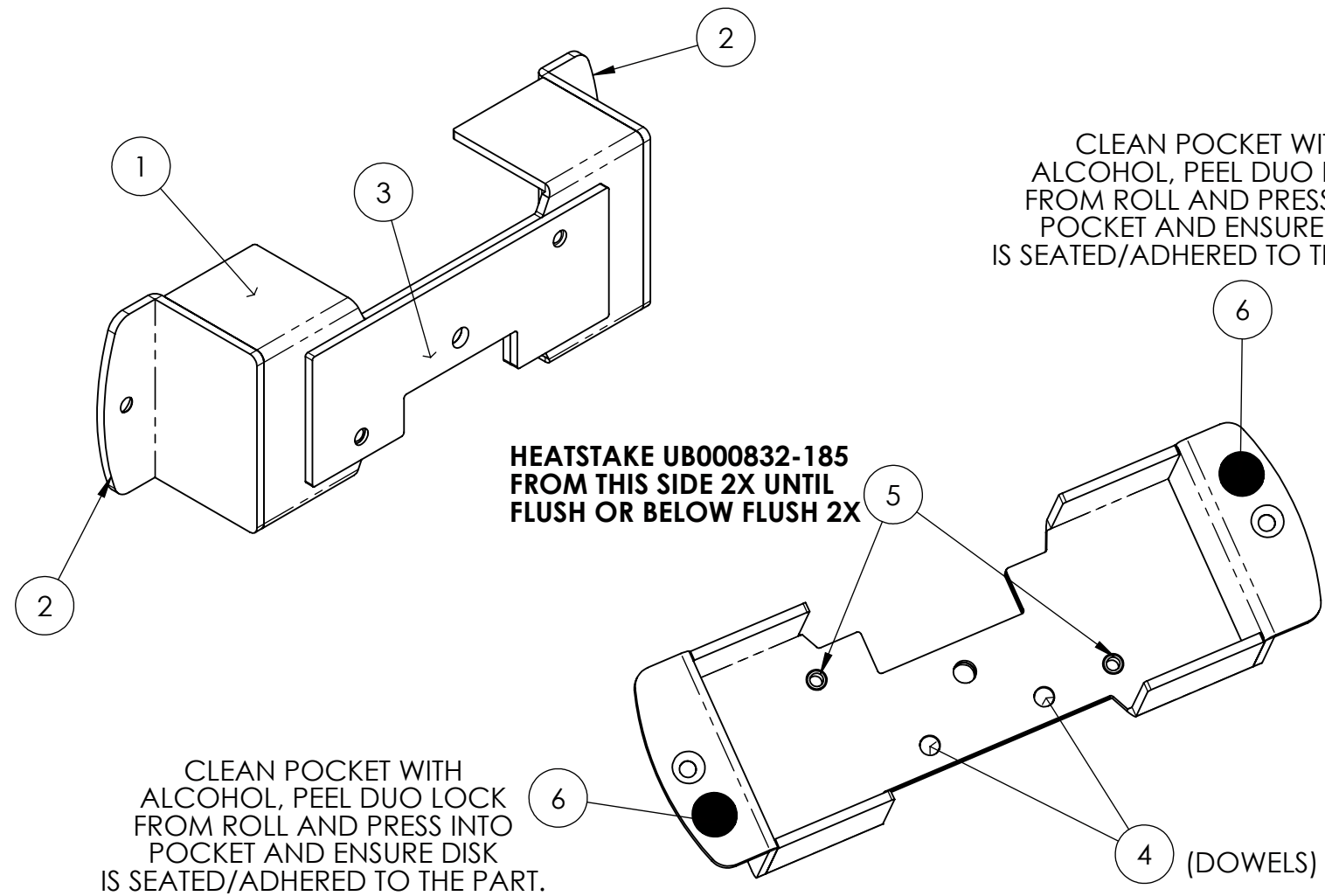

**1. NOTES:**

- 2. MATERIAL: 3mm BLACK H IPS
- 3. FINISH:
- 4. SEE CAD DATABASE FOR UNSPECIFIED DIMENSIONS

**MASTER**

**DATE**

*Crystal Jobe*

8-21-23

2	8-21-23	NARROWED THE BRACKET 5.08mm	
REV.	DATE	REVISION DESCRIPTION	
DIMENSIONS ARE IN MILLIMETERS			
Feature to Feature: $\pm .20$		 <b>ENVISION</b> PLASTICS & DESIGN NO MOLDS NO TOOLING NO PROBLEM FMT# CUSTOMER: PRODCO KB# 3086 DESCRIPTION: BRACKET FOR RECESS KIT '23	
Form to Feature: $\pm .50$			
Form to Form: $\pm .50$			
Pocket Depths: $\pm .25$			
Material Thickness: $\pm 7\%$			
DRAWING #:		3086	REV. 2